

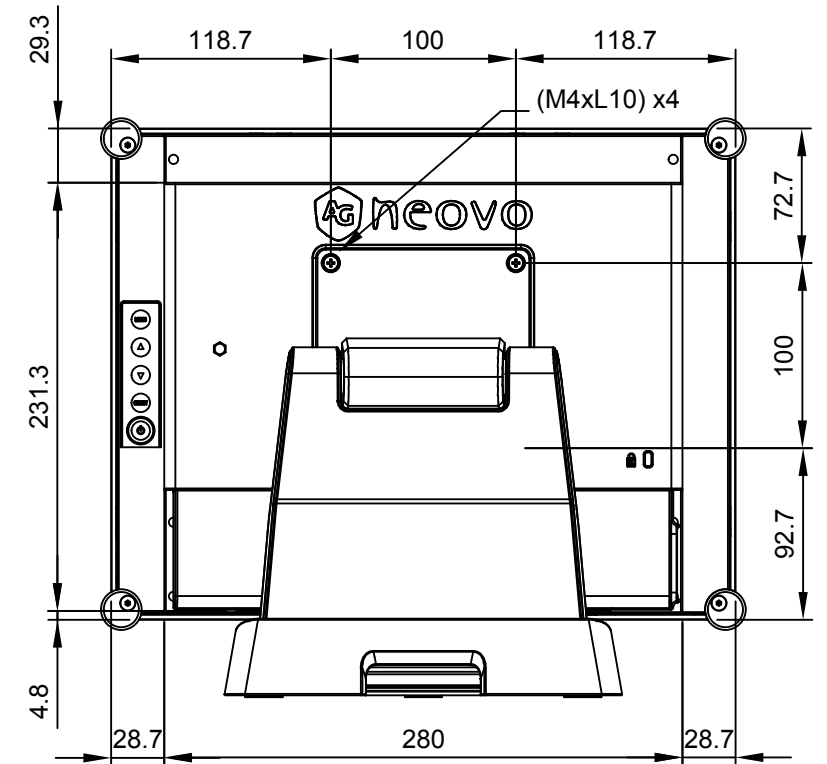

TX-15

Net weight: 4.6kg(with stand)
2.7kg(w/o stand)

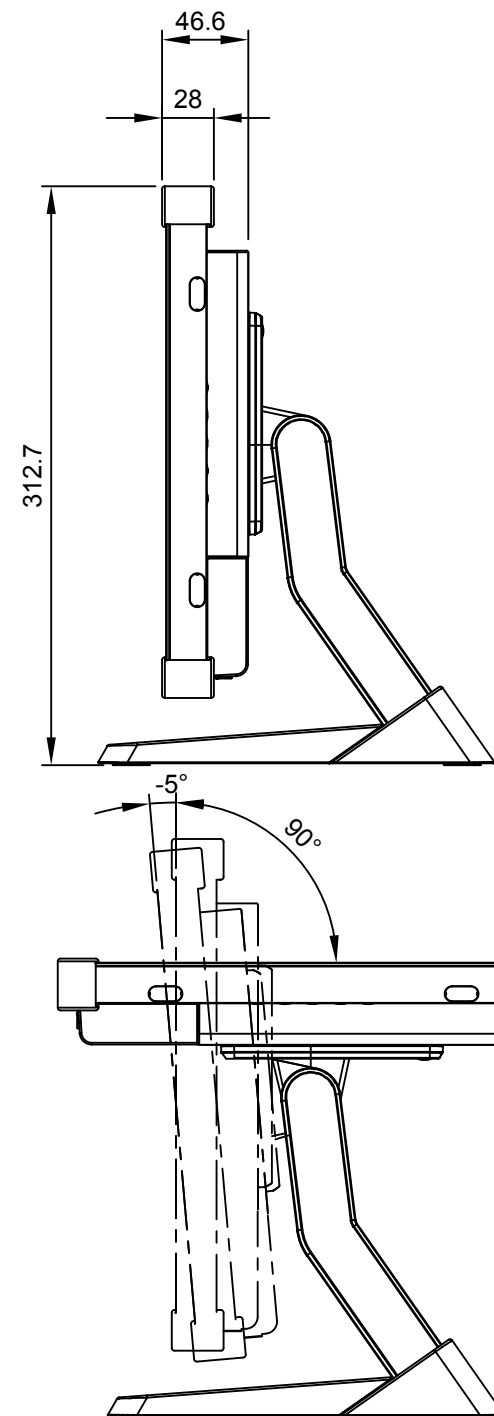
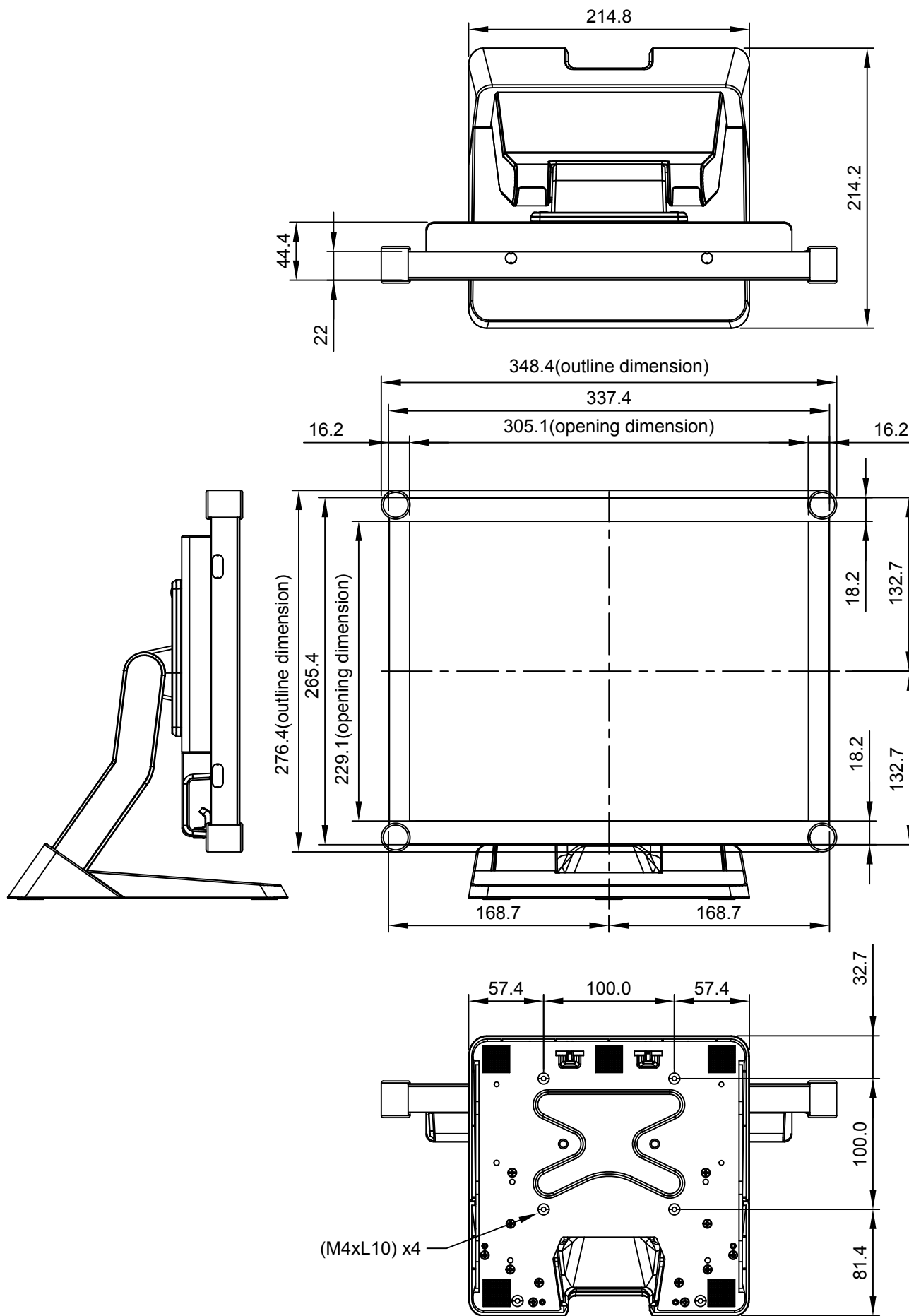

SPECIFICATIONS SUBJECT TO CHANGE WITHOUT NOTICE.

 www.agneovo.com	Model Name: TX-15	
	P/C: TX15A0 / TX15B0	
<small>THIS DRAWING ON THIS PRINT AND INFORMATION BELONG WITH AG Neovo. ANY REPRODUCTION IN PART OR WHOLE WITHOUT WRITTEN PERMISSION OF AG Neovo IS PROHIBITED.</small>	<small>THIRD ANGLE PROJECTION</small>	<small>SCALE 1:1 UNITS mm V.1.03</small>