

**SC-32E**  
 Net weight : 8.1kg (with stand)  
 5.6kg (w/o stand)

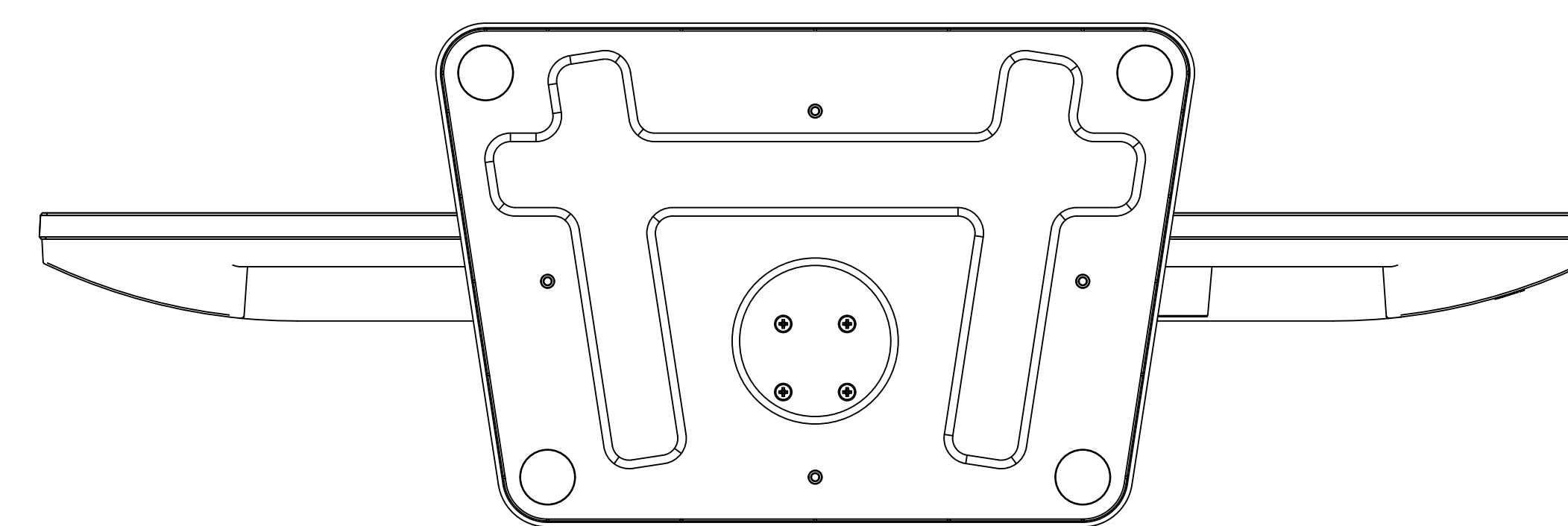
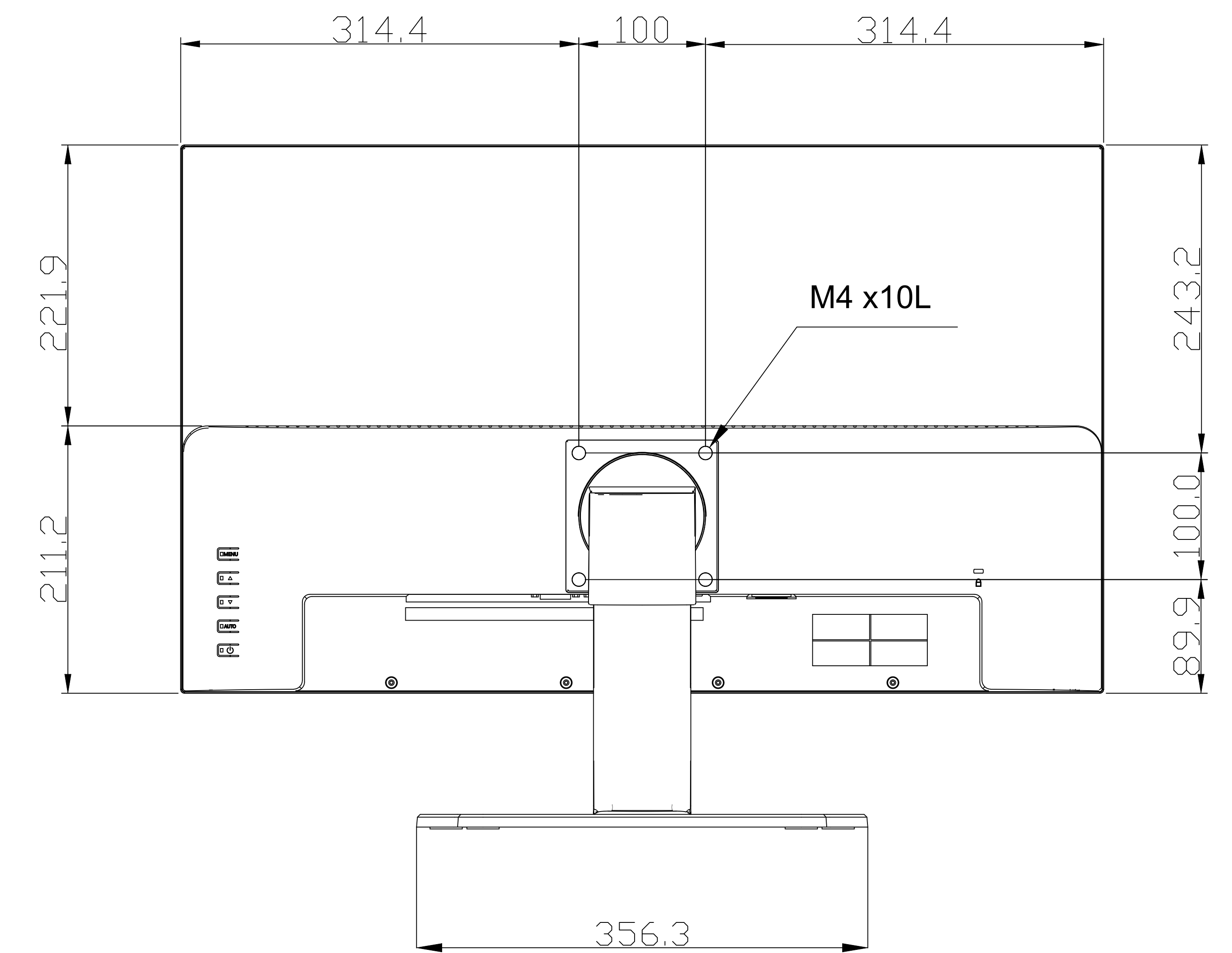
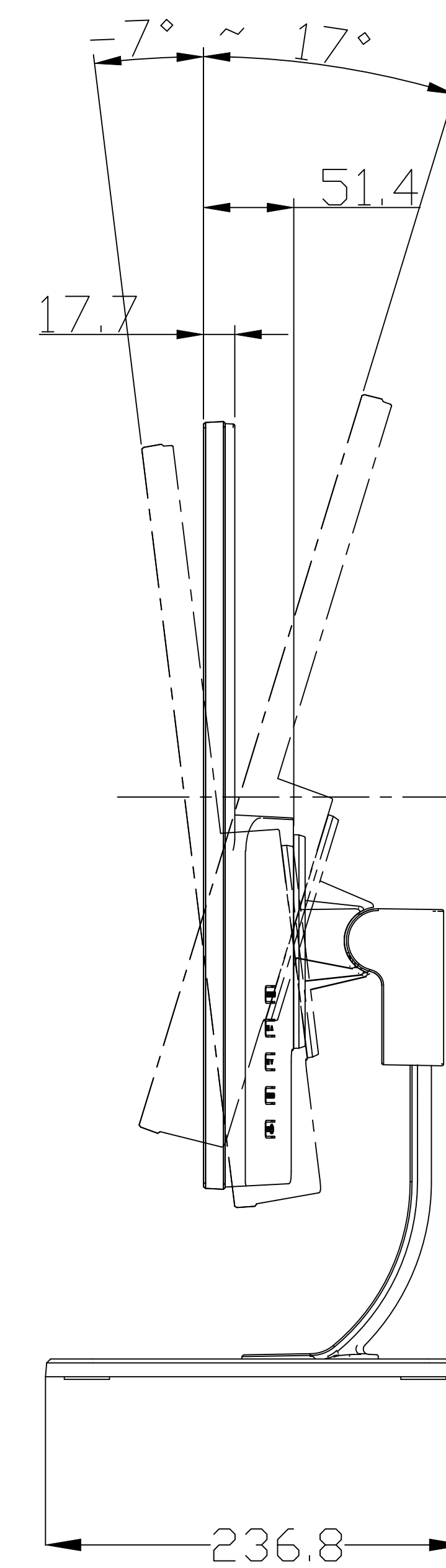
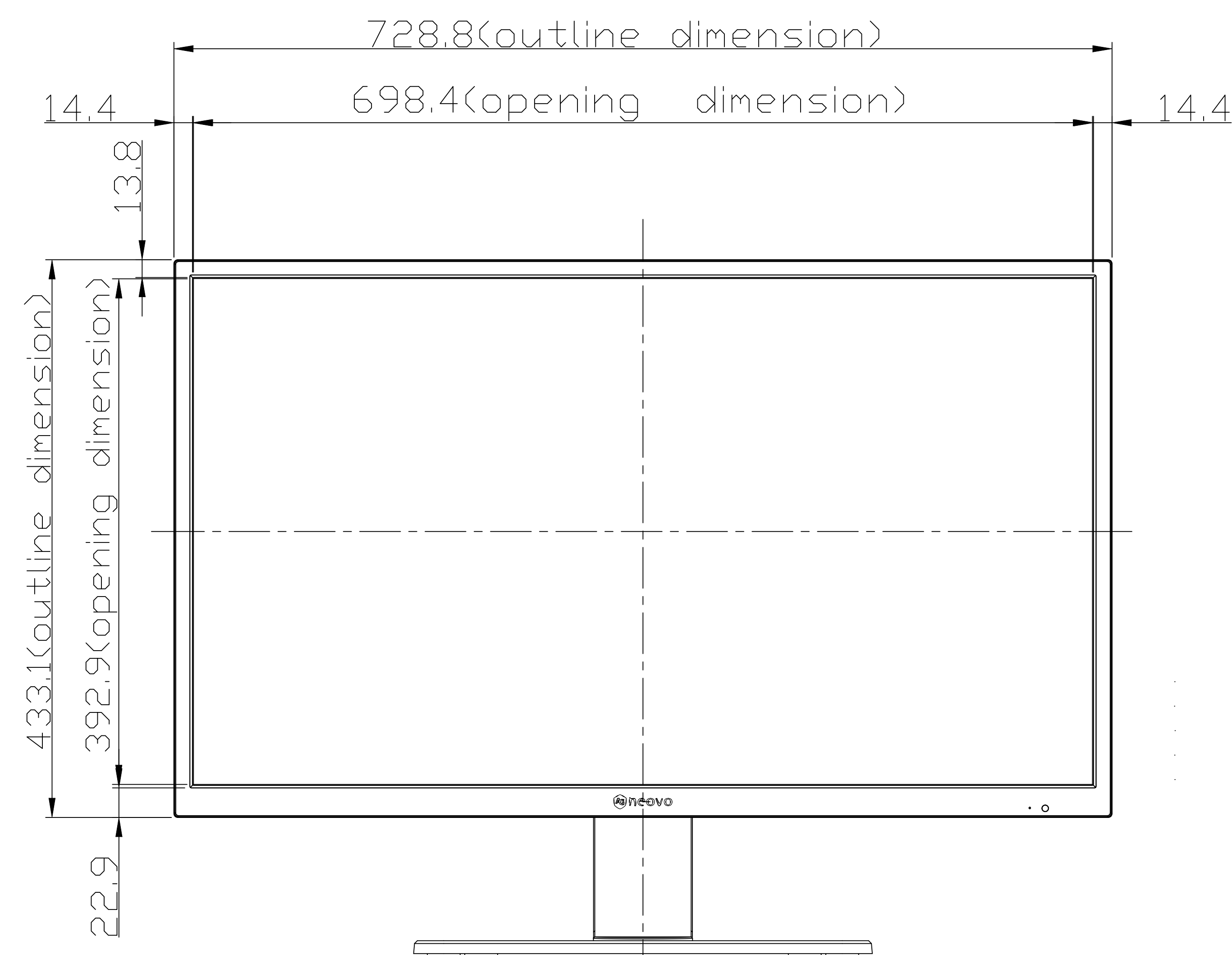
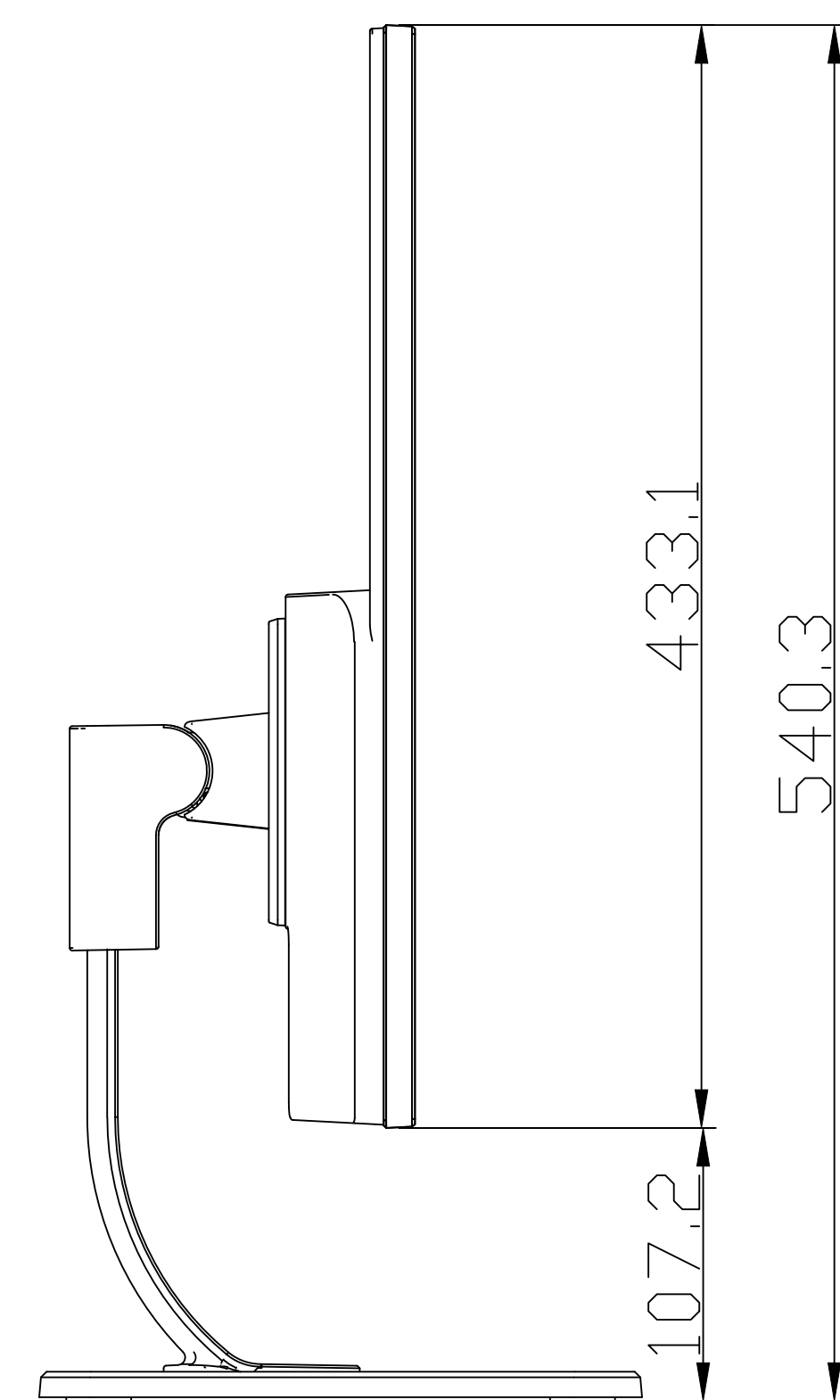
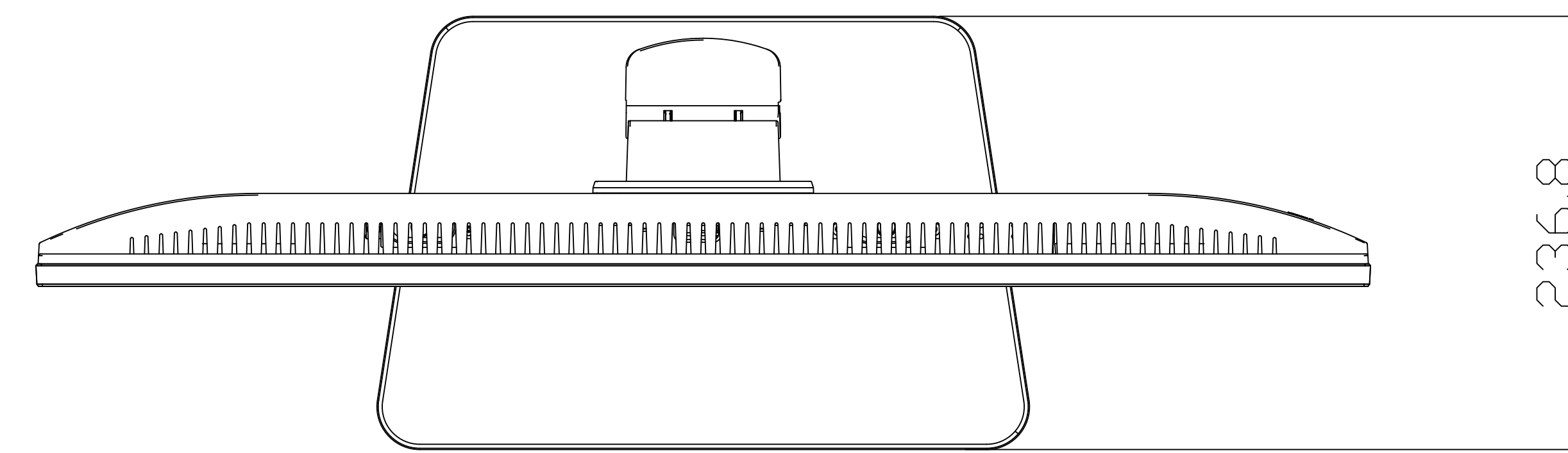

SPECIFICATIONS SUBJECT TO CHANGE WITHOUT NOTICE.

**AG neovo**  
 www.agneovo.com

Model Name:  
**SC-32E**

THIS DRAWING ON THIS PRINT AND INFORMATION BELONG WITH AG Neovo.  
 ANY REPRODUCTION IN PART OR WHOLE WITHOUT WRITTEN PERMISSION  
 OF AG Neovo IS PROHIBITED.

THIRD ANGLE PROJECTION  
 P/C : S32E00 / S32EA0/ S32EB0  
 SCALE | 1:1 | UNITS | mm | V.1.04