

MH-27

Net weight : 6.0 kg(with stand)

3.7 kg(w/o stand)

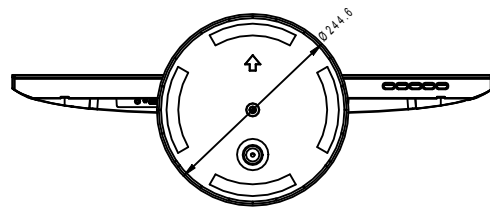
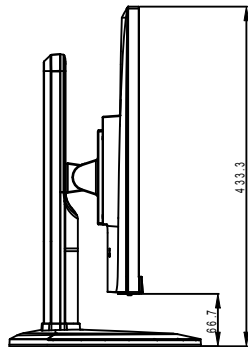
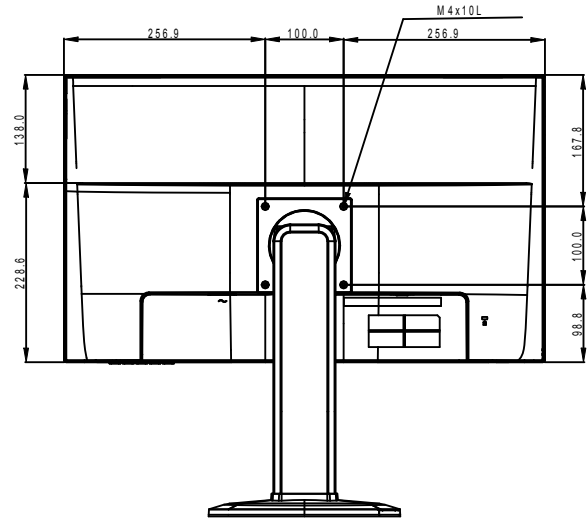
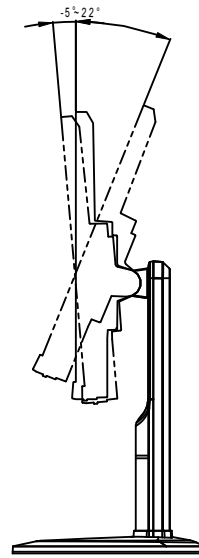
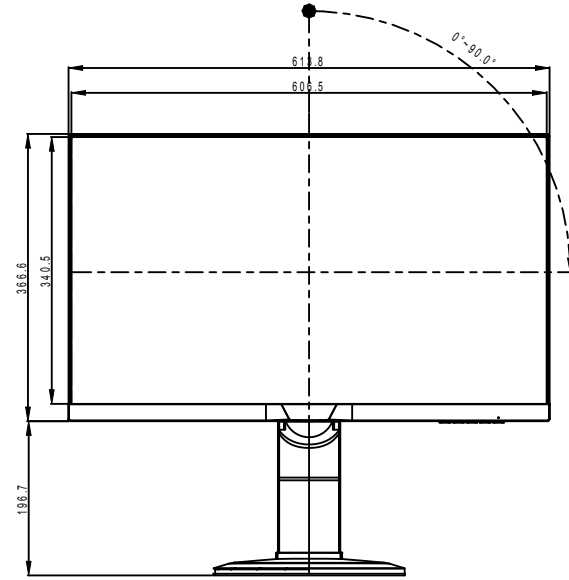
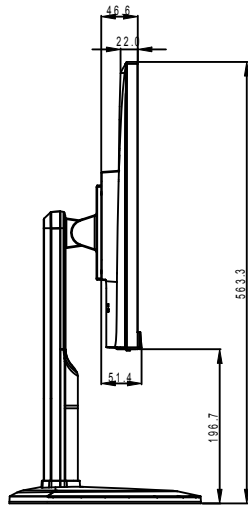

SPECIFICATIONS SUBJECT TO CHANGE WITHOUT NOTICE.

 www.agneovo.com	Model Name:	
	MH-27	
<small>THIS DRAWING ON THIS PRINT AND INFORMATION BELONG WITH AG Neovo. ANY REPRODUCTION IN PART OR WHOLE WITHOUT WRITTEN PERMISSION OF AG Neovo IS PROHIBITED.</small>		P/C:MH2700 SCALE 1:1 UNITS mm V.1.01