

LW-22E

NET WEIGHT: 3.2KG (WITH BASE)

3.0KG (W/O BASE)

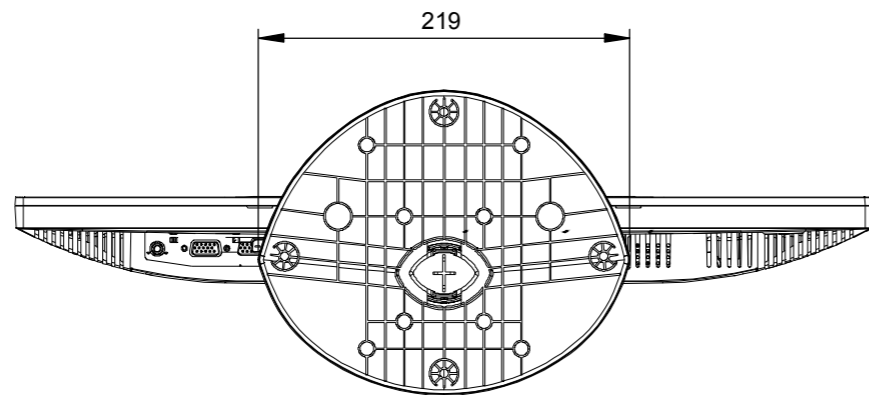
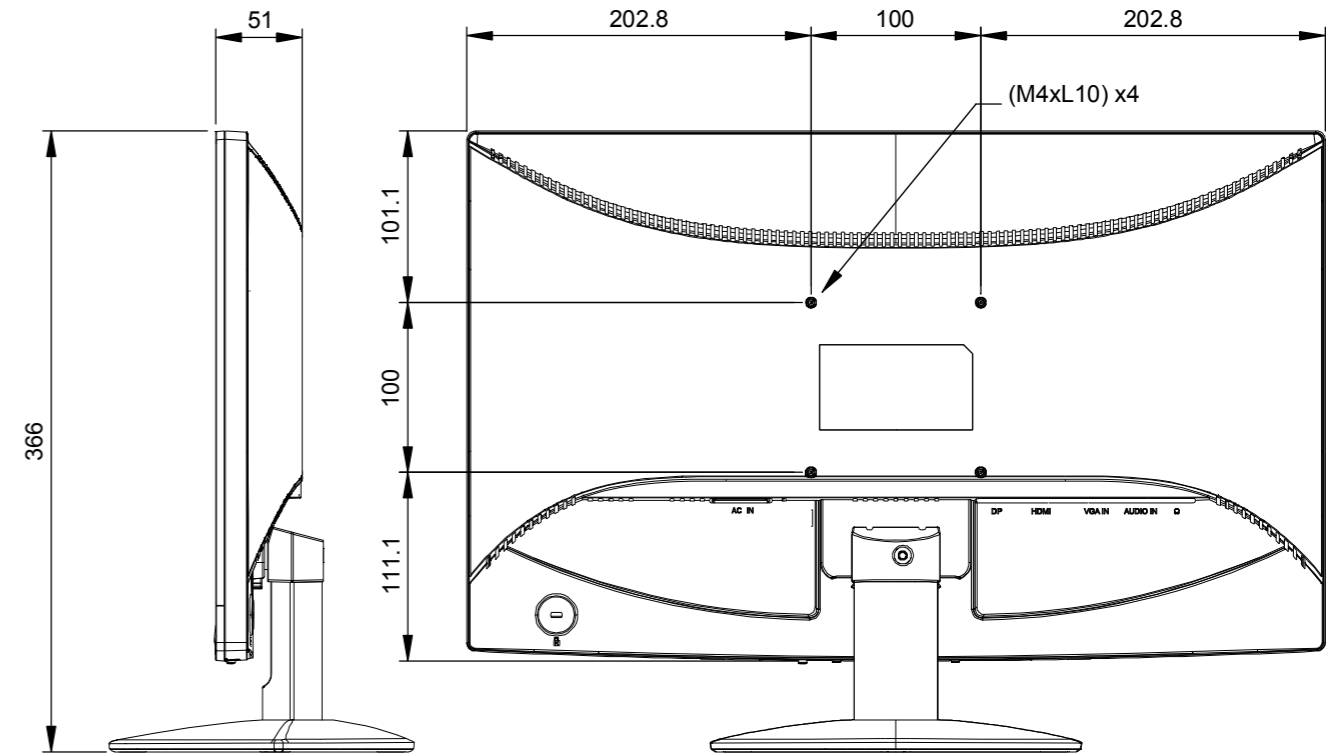
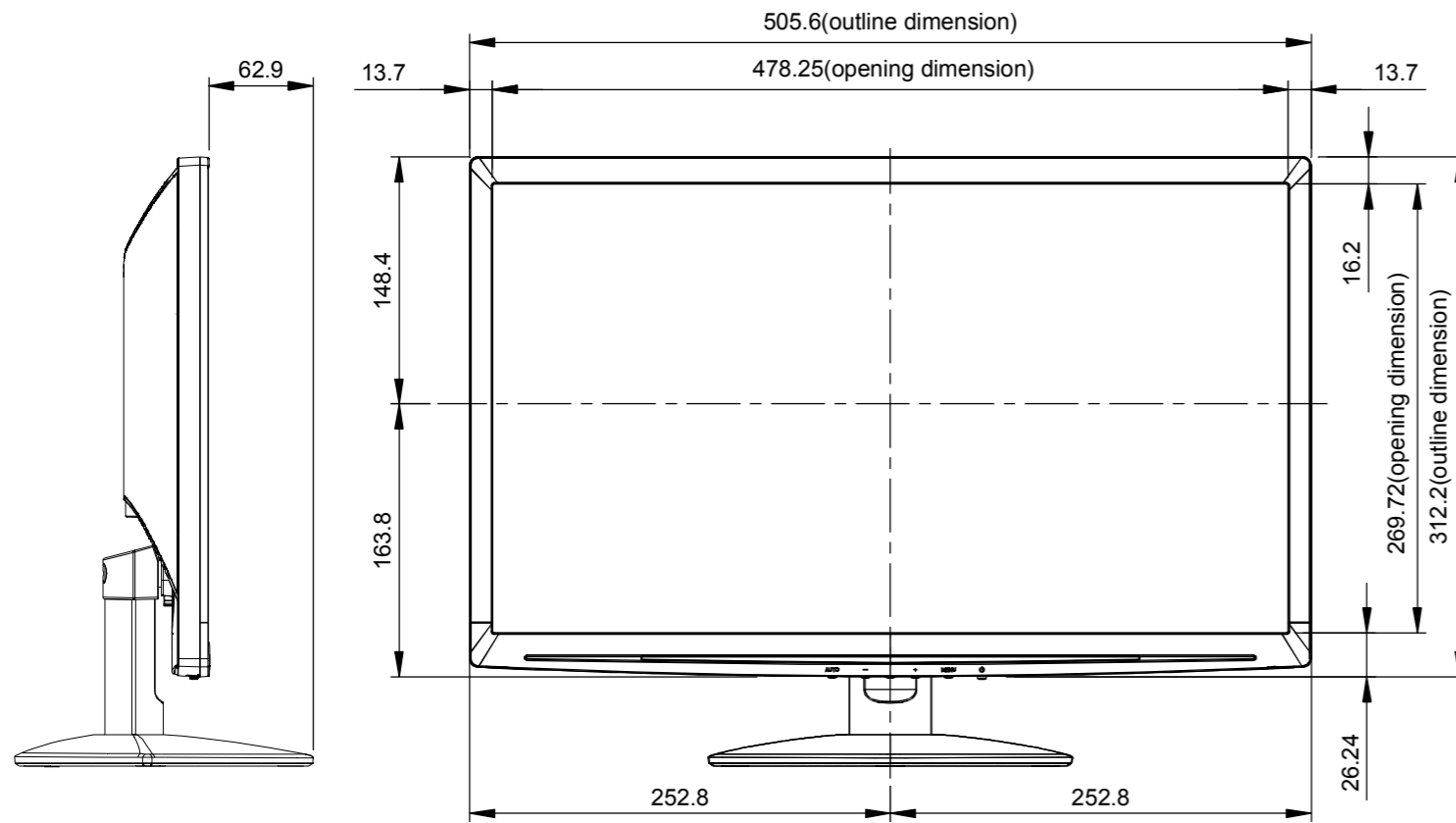

SPECIFICATIONS SUBJECT TO CHANGE WITHOUT NOTICE.

 www.agneovo.com	Model Name:
	LW-22E
<small>THIS DRAWING ON THIS PRINT AND INFORMATION BELONG WITH AG Neovo. ANY REPRODUCTION IN PART OR WHOLE WITHOUT WRITTEN PERMISSION OF AG Neovo IS PROHIBITED.</small>	<small>THIRD ANGLE PROJECTION</small>
SCALE 1:1	UNITS MM V.01